

# MAXPRO Intelligent Charger/Discharger

## X6-Plus

# User's Manual



## INDEX

Specifications.....	2
System Features.....	2
Warnings.....	2
X6-Plus charger layout.....	3
General Setup & Notes.....	4
Li-Po, Li-Ion, Li-Mn, LiFePO4 Operation & Display.....	5
A. Li-Po, Li-Ion, Li-Mn, LiFePO4 Balance Charge.....	5
B. Li-Po, Li-Ion, Li-Mn, LiFePO4 Discharge.....	6
C. Li-Po, Li-Ion, Li-Mn Storage.....	7
D. Li-Po, Li-Ion, Li-Mn, LiFePO4 Balance.....	8
E. Li-Po, Li-Ion, Li-Mn, LiFe Cycle.....	9
NiMH, NiCD, Pb CHG or DHG Operation & Display.....	10
NiMH, NiCD, Pb CYCLE Operation & Display.....	11
ACT Mode for NiMH & NiCD Operation & Display.....	12
Servo Test Mode Operation & Display.....	13
POWER Mode Operation & Display.....	14
SETUP menu Flow.....	15
Error Messages.....	16
Warranty and Non-Warranty Service Conditions.....	16

Thanks for purchasing Maxpro products. Please read the entire manual carefully before using your X6-Plus

## Specifications

Input power:	11~15V DC /15Amp (at maximum charge rate)
Charge current:	0.1~8.0A (0.1A/step)
Discharger current:	0.1~3.0A (0.1A/step)
Max. charge power:	150Watt
Max. discharge power:	15Watt
Balance charge current:	<400mA
Balance accuracy:	<10mV
Voltage tolerance:	0.10%
Capacity display:	0~9999mAH
Supported batteries:	1~6 cells Li-Po, Li-Ion, Li-Mn (2~6 cells in balance charge) 1~8 cells LiFePO4 (2~6 cells in balance charge) 1~18 cells NiMH, NiCd 1~12 cells(2~24V) Pb(SLA)
Temperature control:	Automatic fan speed
PC connection:	USB port
Additional functions:	Servo test (Linear, Speed, Deadband) DC power supply (3.0~30V DC output)
Weight:	450g
Size(LxWxD)	145x100x40mm (5.71"x3.94"x1.57")

## System Features:

1. High power, high current, high-performance power conversion circuit. Maxpro X6-Plus uses advanced DC/DC converter technology with high output conversion efficiency
2. The X6-Plus can be used with four types of Lithium batteries (Li-Po, Li-Ion, Li-FePO4, Li-Mn) and has a built-in balancer.
3. Optimized charge algorithm for NiMH/NiCd
4. Cooling FAN is controlled automatically by internal temperature sensor and provides intelligent protection.
5. 16\*2 backlit LCD that displays the active mode, battery voltage, charge current, pack temperature, capacity (mAh added or removed) and charge/discharge times.
6. Programmable charge settings.  
Li\*\* batteries: normal charge, fast charge, balance, storage, discharge, charge/discharge cycle, and battery monitor.  
NiMH/NiCd & Pb batteries: charge, discharge, charge/discharge cycle.
7. Perfect protection. The X6-Plus has protection for reversed polarity (input or output), low input voltage, battery temperature, charging capacity and battery voltage overrun.
8. Battery internal resistance measurement with PC monitor software.
9. DC power supply mode can provide 3.0~30V adjustable DC to meet your requirement.
10. Built-in servo tester. Linear, Speed, Deadband of servos can be tested.
11. Firmware upgradable via USB port. The charge/discharge data can be recorded & analyzed by PC monitor software & Battery analyzer software.

## Warnings:

- Use a high quality power supply for input power source.
- Do not allow water, moisture, metal wires or other conductive material into the charger.
- Keep the charger away from children or pets at all times.
- Always be sure that the charger is properly configured for the correct battery type .
- Be sure that your lithium battery pack balance connector matches the multi-adapter type connected to the charger.
- Beware that the temperature of the charger shell & battery packs will increase during charge/discharge at high power.
- Do not exceed the battery manufacturer's suggested maximum charge rates.
- Never charge batteries unattended.
- NEVER attempt to charge "non-rechargeable" cells.
- ACT charging mode should start with battery packs connected.
- Properly insulate and regularly inspect all connectors to eliminate the possibility of short circuit. Damage caused by output short circuit is not covered by warranty.
- Do not open the case of the charger under any circumstances. Doing so will void the warranty.

**X6-Plus charger layout**



Check X6-Plus charger and the standard accessories you get. The following Standard items are included in the package. Contact your supplier if missing part or damage is found.

**Standard items:**

- Maxpro X6-Plus charger with input cables & clips
- One pair of output cables & alligator clips
- One temperature sensor
- One USB data cable
- One balance multi-adapter
- One CD (User's manual, PC monitor software, Battery Analyzer software inside)

**Optional parts:**

- Multi-connector output cable
- Multi-Battery Charging Adapter (2S/3S)

**LCD display abbreviations:**

- ACT: Activation mode
- CHG/CH: Charge mode
- DHG/DH: Discharge mode
- STO: Storage mode
- BAL: Balance mode
- CYCLE: Discharge/Charge cycle mode
- ST: Initial charging of Li-xx battery
- CC: Constant current
- CV: Constant voltage
- TR: Trickle charging of NiMH/NiCd Battery
- GV: Imbalance voltage between cells

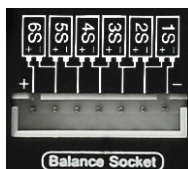

The cell order of balance socket is 123456 from negative to positive.

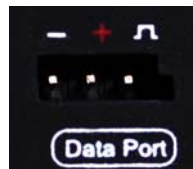

Data port is used for temperature sensor or servo connection.

**General Setup & Notes**

Before Charging/Discharging is started, Pls choose an appropriate AC/DC input power source. When charging high voltage batteries at high current (charger output 150W) the AC/DC Power Supply should be 12V minimum with rating of 160W or more, to ensure reliable performance. The X6-Plus allow you to use lower-rated power supplies reliably, but that total charger output wattage will be limited accordingly.

1. Attach X6-Plus to an appropriate DC power supply.
2. Connect the Input Cables (Red+ & Black-) on left side of X6-Plus to the DC power supply. Then wait for the initialization to complete and the "No Battery" message to be displayed..
3. Connect the output cables to the Output Port on the right side of X6-Plus first!! then connect the output cables to your Battery Main wire Connector (in Series charging)

To perform a balance charge do the following steps..

4. Connect the Balance Multi-Adapter to the balance socket on the right side of X6-Plus
5. Connect your Lithium battery Balance Connector to the Balance Multi-Adapter.

**Suggestion: ALWAYS USE THE BALANCER(S) WHEN CHARGING LITHIUM BASED PACKS FOR SAFETY!!**

**NOTE:**

- Please make absolutely sure that you properly identify the type of battery you are charging, the capacity in mAh, and the number of cells wired in series and the pack voltage !!
- Please consult the documentation or labels provided with your battery to determine the correct capacity setting. It is very important to get this right, as the charger uses the capacity setting to determine nominal charge rate (amperage), capacity protection and safety termination. Incorrect settings could damage the battery, or result in an incomplete charge
- CAPACITY is selected in mAh. Selection is in increment/decrement of 100mAh. CURRENT is set in Ampere (divide mAh by 1000 to get Amperage). For 2100mAh, 2.1A for 1C, and 4.2A for 2C and so on.
- After charging is finished, always disconnect the Battery main wire connectors from Output Cables set first, then disconnect Output Cables set from charger.
- Be very careful to choose the correct voltage for the different types of battery. The following battery parameters are for reference.

	Li-Po	Li-Ion	Li-Mn	Li-Fe	NiMH/NiCD	Pb
Voltage level	3.7V/cell	3.6V/cell	3.7V/cell	3.3V/cell	1.20V/cell	2.0V/cell
Max. charge voltage	4.2V/cell	4.1V/cell	4.2V/cell	3.6V/cell	1.60V/cell	2.45V/cell
Allowable fast charge current	1C or less	1C or less	1C or less	4C or less	1C or less	0.4C or less
Discharge voltage cutoff level	3.0V/cell	2.75V/cell	2.75V/cell	2.0V/cell	0.85V/cell	1.80V/cell



**DEC/INC**, Scroll though the parameter values for Battery type, Cell numbers, Battery capacity, Charge/Discharge current, Operation mode. And turn the LCD page between Li\*\* total voltage & cell voltage.

**START/ENTER**, Confirm the setting and skip to next parameter, Start Charge/Discharge

**ESC/STOP**, Cancel the setting and exit to last parameter, Stop Charge/Discharge

Li Po Normal CHG  
6S 2200mAh 2. 2A

**Cursor indication:** When the cursor flashes, DEC/INC can be used to set the parameter. e.g. "2200" flashing, Use DEC/INC to scroll though the setting of capacity. "Gray" means the cursor is flashing in this manual.

**Timer:** When you start Charging or Discharging in any mode, an internal timer starts counting at the beginning of these cycles and is displayed on the charge and discharge screens.

**Li-Po, Li-Ion, Li-Mn, LiFePO4 Operation & Display**

**A. Li-Po, Li-Ion, Li-Mn, LiFePO4 Balance Charge**

Connect the Li\*\* Battery Main wire Connector & Balance Connector to X6-Plus

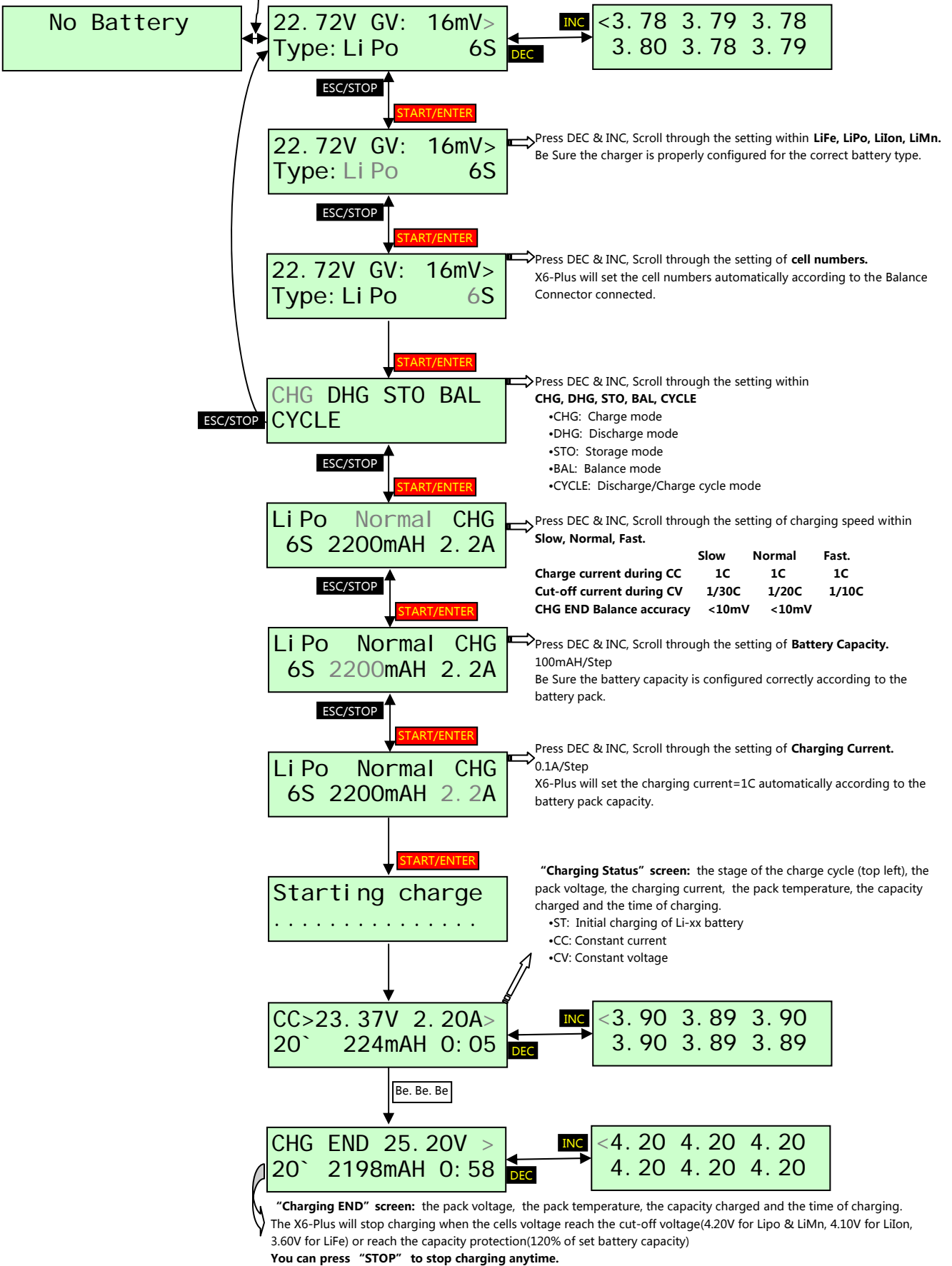

**B. Li-Po, Li-Ion, Li-Mn, LiFePO4 Discharge**

Connect the Li\*\* Battery Main wire Connector & Balance Connector to X6-Plus

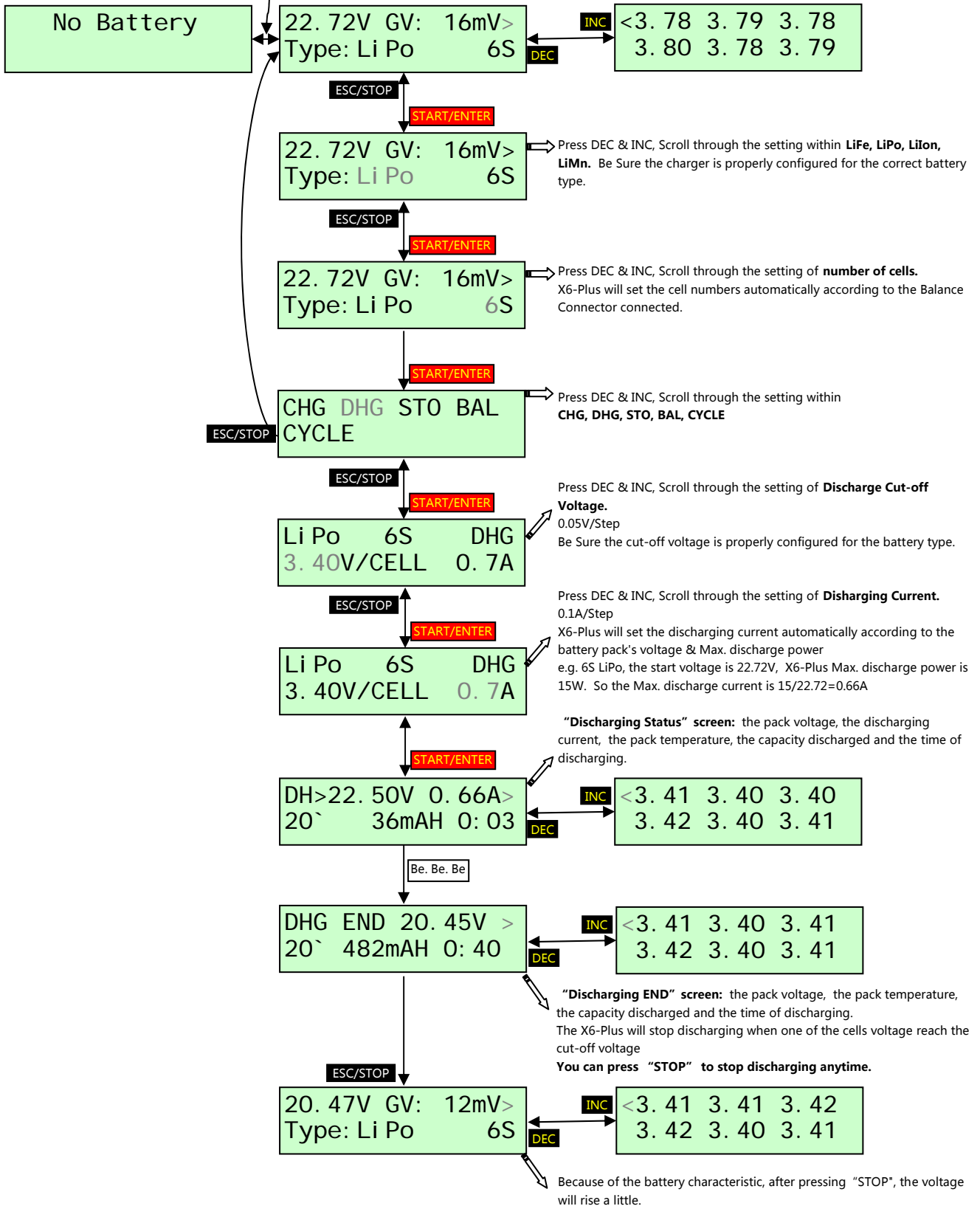

C. Li-Po, Li-Ion, Li-Mn Storage

Connect the Li\*\* Battery Main wire Connector & Balance Connector to X6-Plus

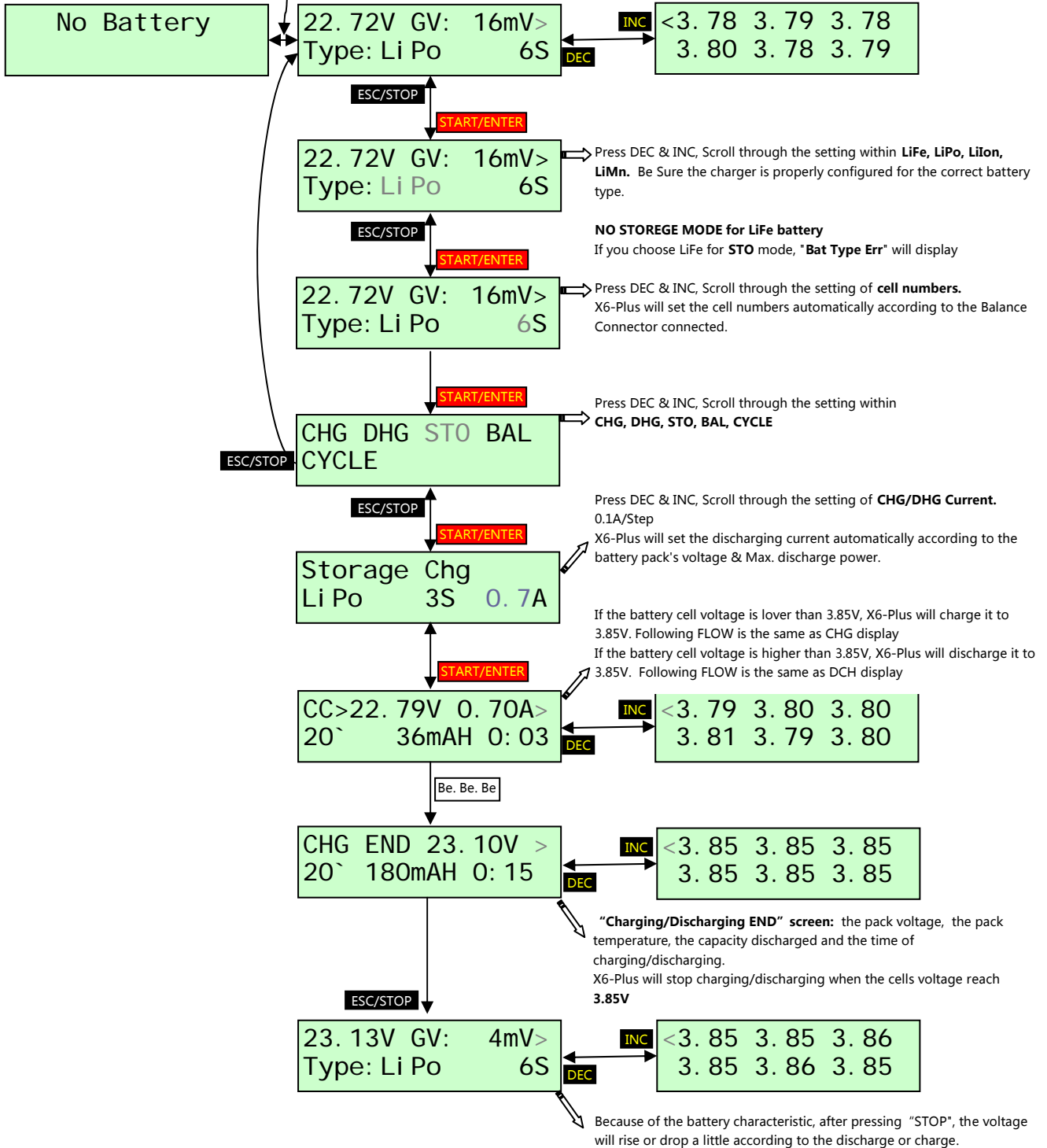

**D. Li-Po, Li-Ion, Li-Mn, LiFePO4 Balance**

Connect the Li\*\* Battery Main wire Connector & Balance Connector to X6-Plus

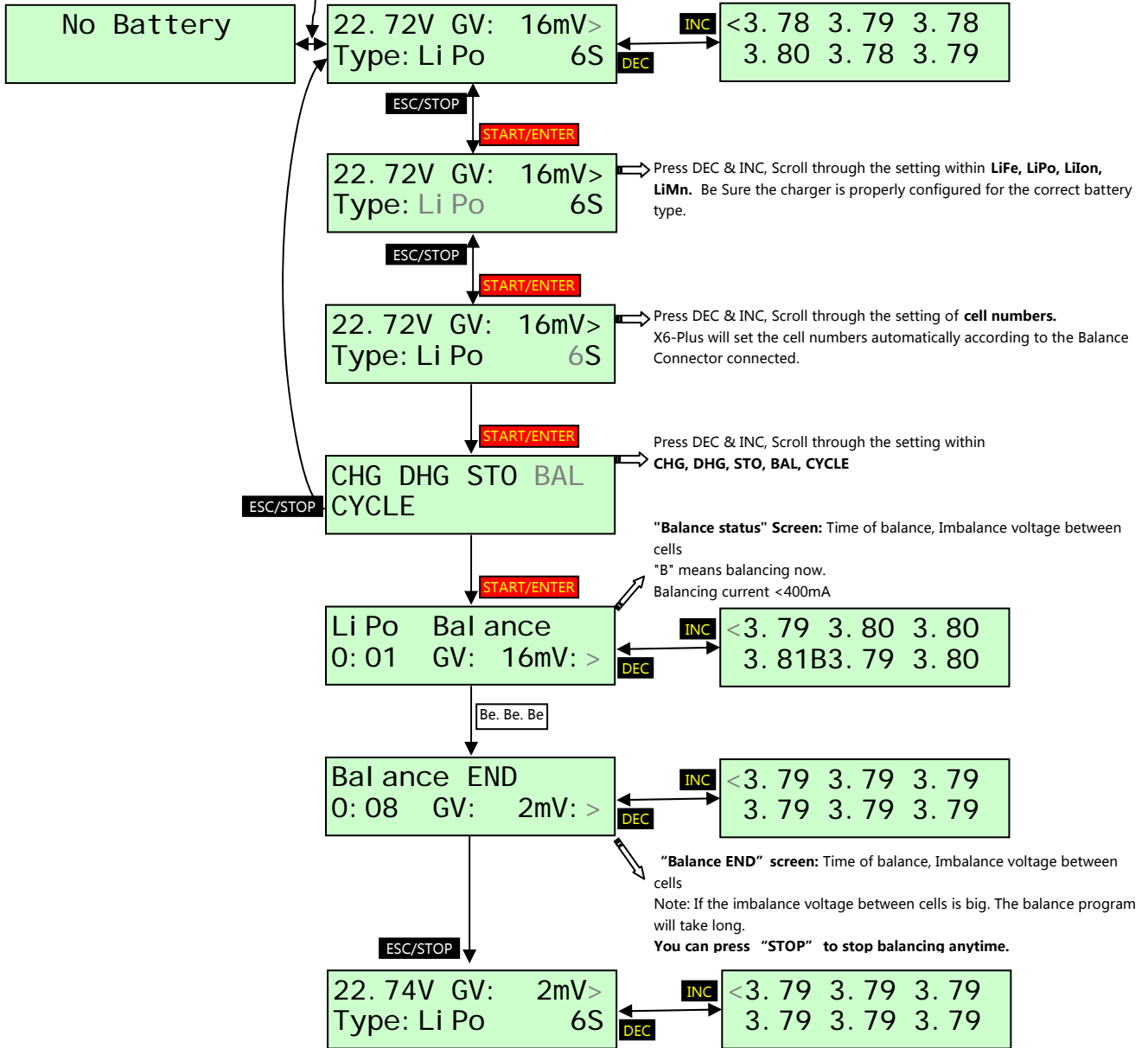

**E. Li-Po, Li-Ion, Li-Mn, LiFe Cycle**

Connect the Li\*\* Battery Main wire Connector & Balance Connector to X6-Plus

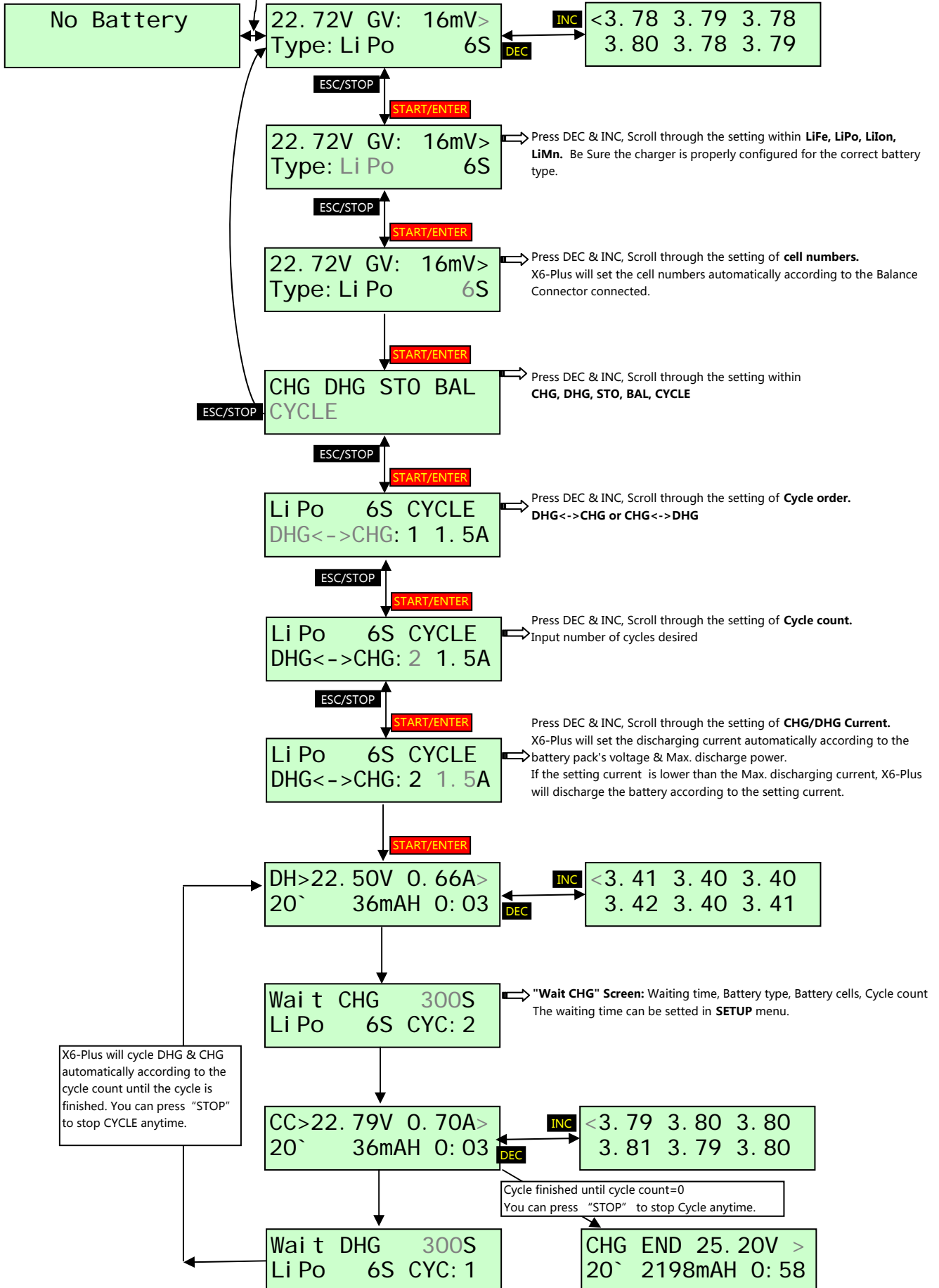

**NiMH, NiCD, Pb(Lead-Acid) CHG or DHG Operation & Display**

Connect the Ni\*\* or Pb Battery Main wire Connector to X6-Plus  
Suggestion: Temperature sensor should be connected to X6-Plus and touched with the battery.

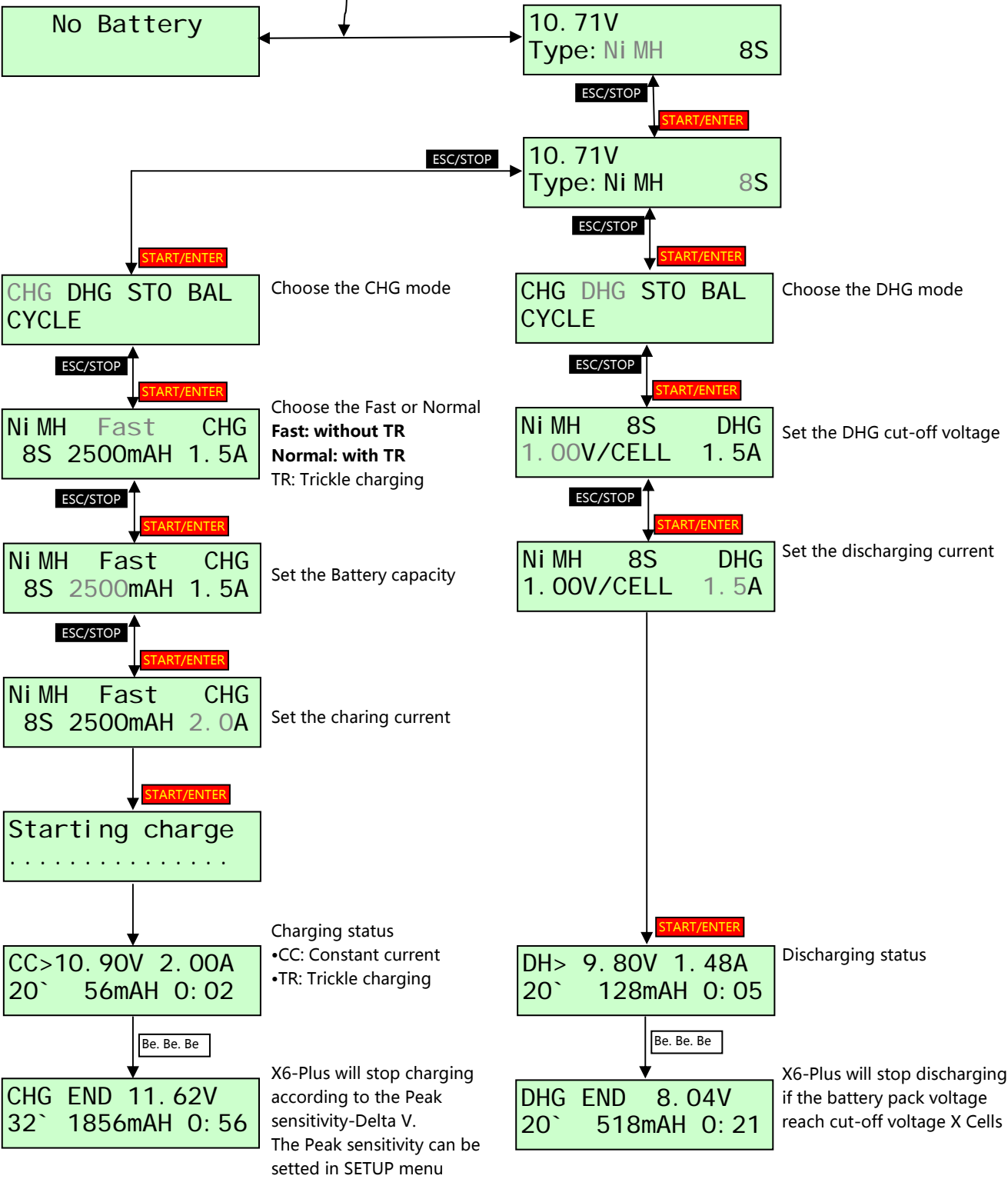

**NiMH, NiCD, Pb(Lead-Acid) CYCLE Operation & Display**

Connect the Ni\*\* or Pb Battery Main wire Connector to X6-Plus  
Suggestion: Temperature sensor should be connected to X6-Plus and touched with the battery.

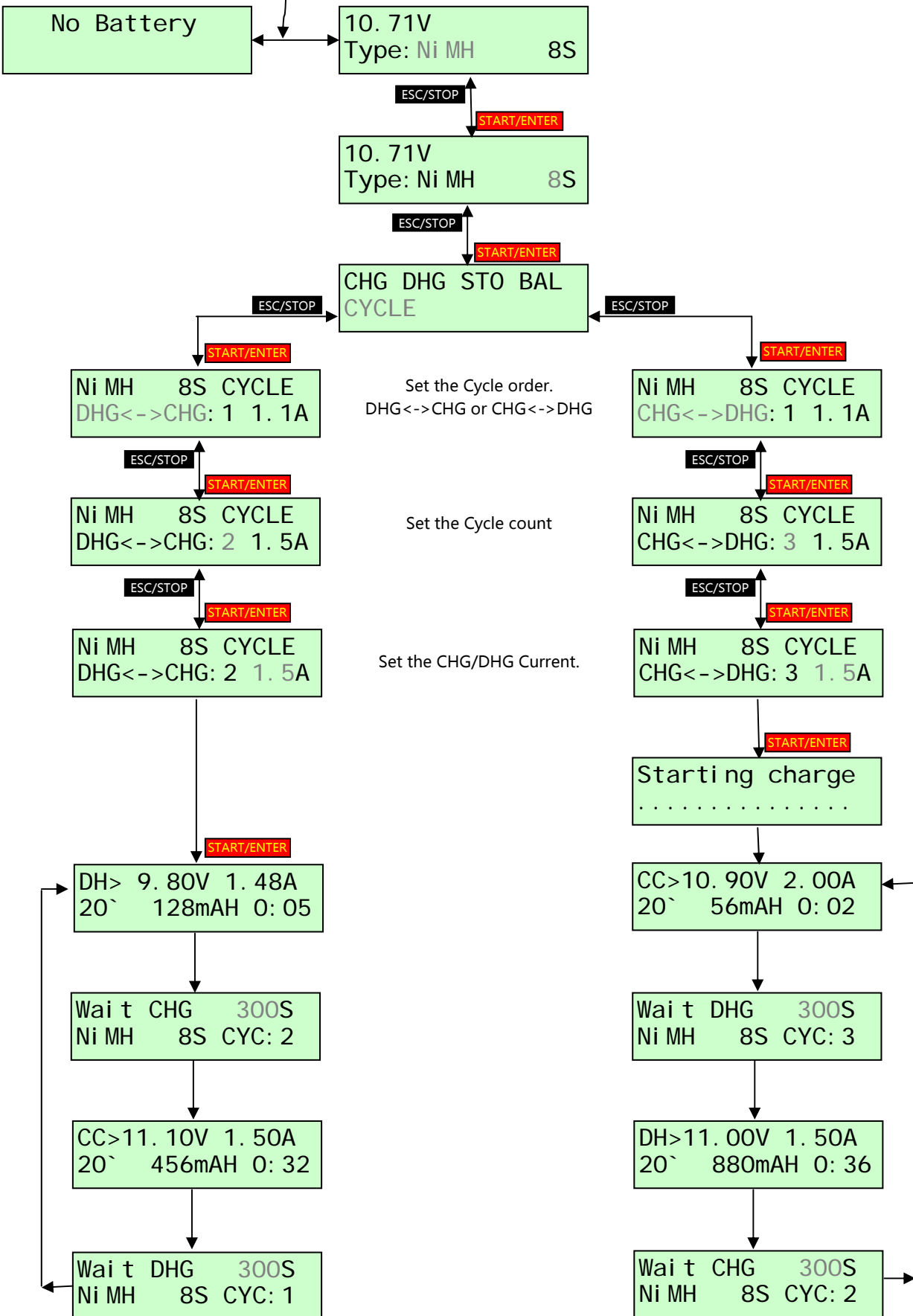

**ACT Mode for NiMH & NiCD Operation & Display**

ACT Mode can charge the NiMH or NiCD battery when the voltage can't be detected by X6-Plus, It allows the user to override the voltage sensing and force the charge cycle to run.  
**Be sure you know the battery specification & characteristic very well before you use ACT Mode.**

Connect the NiMH/NiCD Main wire Connector to X6-Plus.  
 Bu sure the connection is right. If X6-Plus can't detect the voltage.  
 Pls press "ENTER" to get the ACT Mode

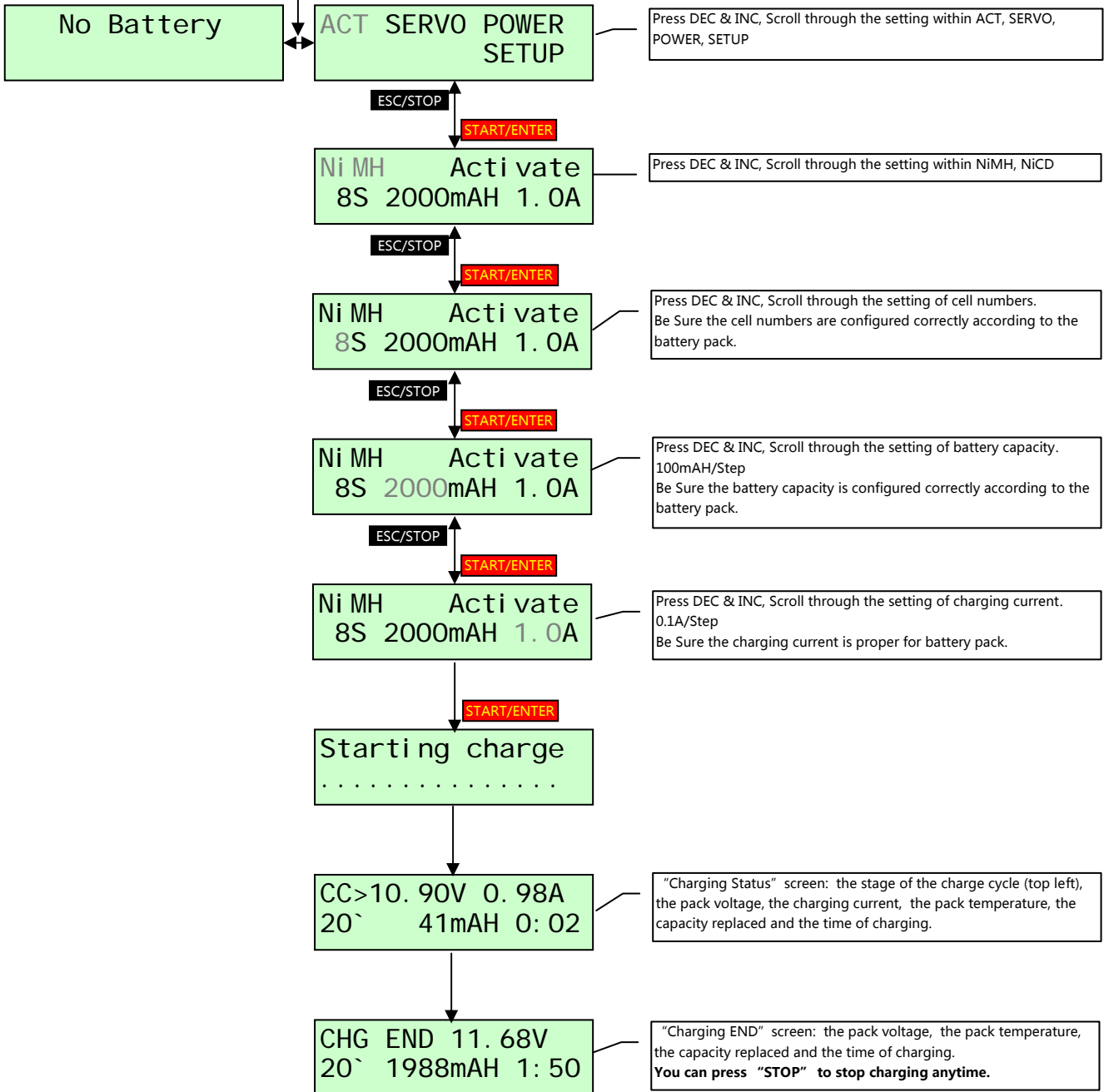

## Servo Test Mode Operation & Display

Servo Mode can provide the Linear, Speed and the Deadband test.  
 The servo load current should be lower than 500mA

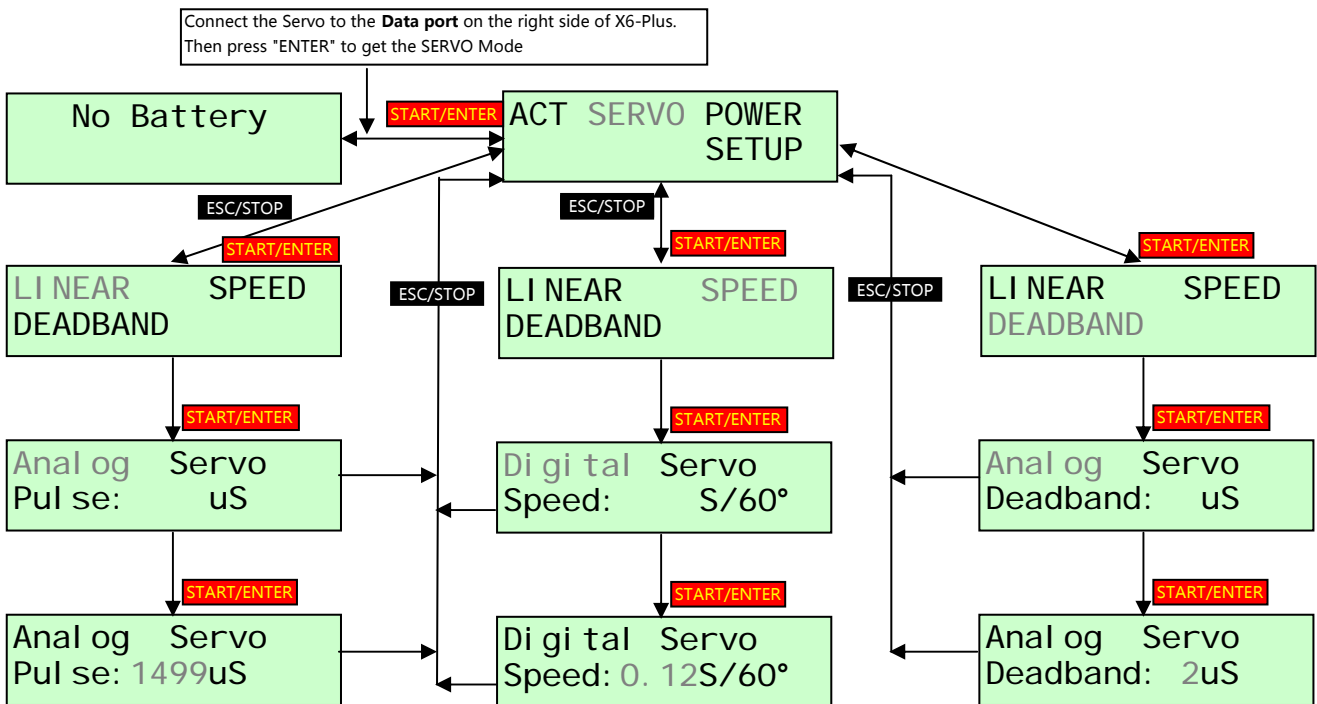

### Linearity Test

1. Choose servo property(Analog or Digital)
2. Hold the DEC to scroll through the pulse width to the lowest point. Hold the INC to scroll through the pulse width to the highest point.
3. Check the servo running smooth or not to get the information of linearity, and search the shake point of damaged servo.

### Speed Test

Every servo has its own responding speed. and after a period of using, the speed will change also. By testing the speed, we can get information of actual speed and select the servos with similar speed (e.g. CCPM helicopter)

1. Choose servo property(Analog or Digital)
2. Press "ENTER" to run the speed test program. X6-Plus will output **5V DC** to turn the servo left and right automatically. Servo speed is displayed on the LCD (**Base on 5V DC & 60° turn**)
3. Press "STOP" to exit the function.

### Dead band Test

Dead band Test can give the feedback of servo sensitivity. Generally, the dead band of normal servos shall be 1uS. However, because of the precision of servo and assembly, the actual dead band will be different. By testing the dead band, the actual size of dead band can be defined, which can help you select servos with the same sized dead band.

1. Choose servo property(Analog or Digital)
2. The beginning dead band is 0uS. the servo is at the middle position. Press DEC or INC to set the value(1uS/Step), until the servo move slightly & regularly itself. The value is the dead band.

**NOTE: The servo is at the middle position when the dead band value 0uS is setted.**

**POWER Mode Operation & Display**

Power Mode can provide 3.0~30V adjustable DC to meet your requirement.

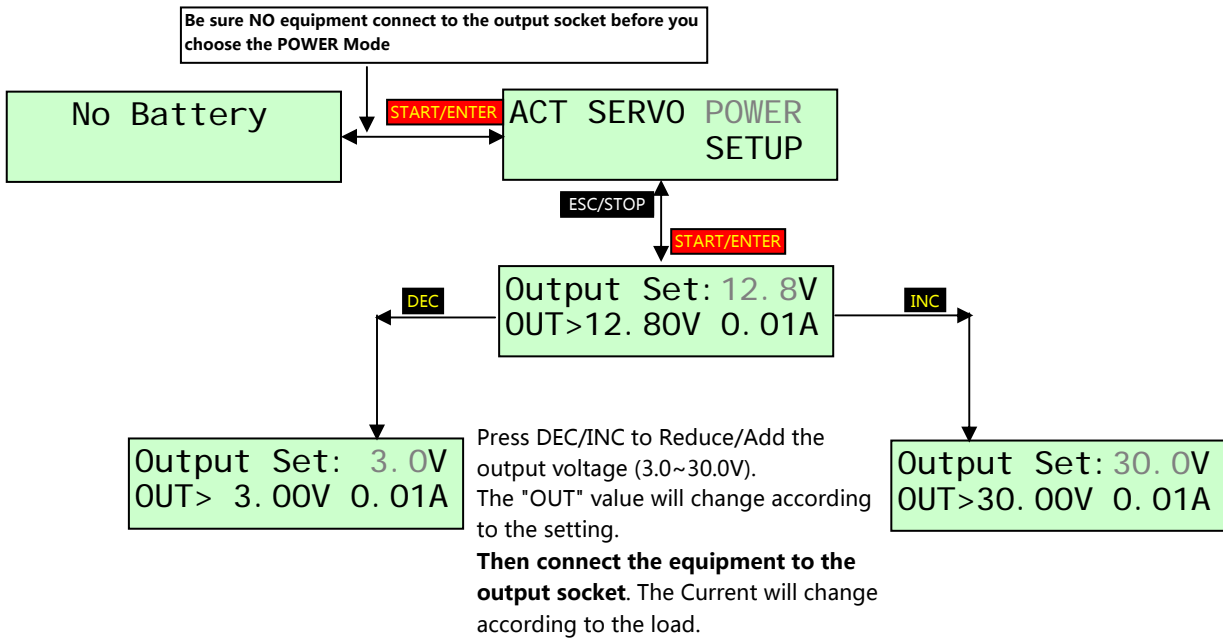

**SETUP menu Flow**

Following items can be set in SETUP menu.

Key Beep ON/OFF, Buzzer ON/OFF, Temperature Cut-off, NiMH/NiCD Peak, Cycle wait time, Input power low.

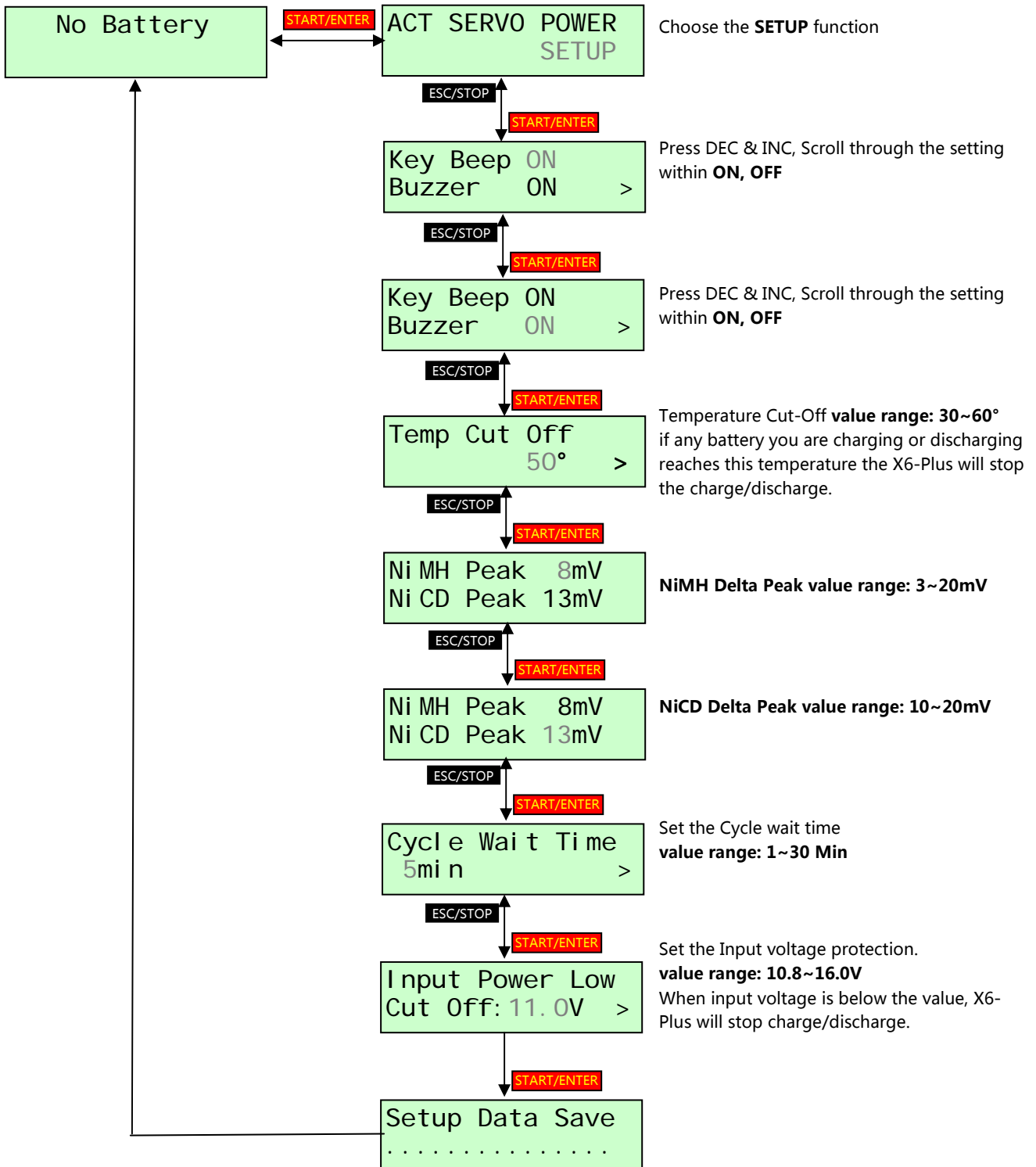

## Error Messages

### Connecti on Break

If the battery becomes disconnected during an operation.

### Battery Temperature Over

Battery temperature is too high to be charged.

### Charge Capacity Over

The charged capacity reach 120% of setting capacity.

### BAT INCORRECT POLARITY

Output battery is connected to the output in reverse polarity(switch +/-).

### Bat Type Err

Mistake the battey type for the function.

## Warranty and Non-Warranty Service Conditions

Thanks for purchasing the products made by MAXPRO. We are pleased to provide the best after-sales services for our customers.

- Our after-sales service for our charger includes:
  - Each charger is free from defects in materials and workmanship for a period of 1 year from the customer's original date of purchase.
  - Lifetime repair and maintenance service (It will be charged, we call it non-warranty service);
  - Free software upgrade service.
- The product is covered under warranty service if it is coincident with both of the following conditions:
  - The product was originally purchased within the past one year. The original date is determined by the date written on the valid receipt or invoice.
  - The problem is caused by the quality defects in materials or workmanship.
- Nonresponsibility:

If there is any situation as below, then the product is not covered under warranty, then it will get non-warranty service.

  - A valid sales receipt or invoice within one year warranty period is not provided.
  - Product was damaged due to the changing / decomposing taken by the customer himself.
  - Product was damaged due to incorrect use or application, exposure to water or any other liquid, bang, knock and etc.
- Software upgrade is always free on our website. Pls download it yourself.
- Shipping cost
  - If the product is covered under warranty, Please contact the Maxpro's Distributor in / near your location for the warranty service to avoid expensive shipping and handling fees. If customer want to send the charger to MAXPRO for service, the shipping cost from customer to Maxpro is paid by the customer, and Maxpro will pay for the shipping cost for returning the repaired product to the customer.
  - If the product is not covered under warranty, all the shipping cost is paid by customer.
- After-sales service processing:
  - If the product is out of work, and the customer determines it is damaged after careful check and test. Please directly contact the person in charge of after-sales service of your local dealer or Maxpro(Contact us through telephone,e-mail and etc), and describe the charger's situation in detail.
  - The after-sales service person will help the customer to confirm if the defected product actually needs to be repaired or the problem is just caused by mistakenly use and / or the another problem exists in the system—such as a defect in the input power, battery,etc.
  - If the product is determined to be repaired, please ship the defective product & situation description to your local dealer or Maxpro.
  - Maxpro evaluates the damage level of the defected products. If it needs to be charged, Maxpro will contact the customer through telephone or e-mail or some other methods, and begin to repair the product after the service fee is confirmed by the customer.
  - The service time for most defected products is within 5 working days from the date when the dealer or Maxpro receives the product. And the repaired product will be returned to the customer in time.
- The authority of interpretation of warranty service conditions belongs to Maxpro RC Technology Co., Ltd.